

Brass Ball Valves

Two-Piece Body • Full Port • Blowout-Proof Stem • TFE Seats

1/4"-2" 600 PSI/41.4 Bar Non-Shock Cold Working Pressure

2 1/2"-4" 400 PSI/27.6 Bar Non-Shock Cold Working Pressure

CONFORMS TO MSS SP-110 • CSA TO ASME B 16.44 AND CR 91-002

• FM APPROVED • UL LISTED • NSF/ANSI 61-8

MATERIAL LIST

PART	SPECIFICATION
1. Handle	Steel, Plated
2. Nut, Handle	Steel, Plated
3. Pack Gland	Brass ASTM B 16 Alloy C36000
4. Packing, Stem	Virgin PTFE
5. Washer, Flat	430 Stainless
6. O-Ring (Stem Seal)	Fluorocarbon (FKM)
7. Washer, Thrust	Reinforced PTFE
8. Stem	1/4" - 1" & 2 1/2" - 4" 1 1/4" - 2" Brass ASTM B 16 Alloy C36000 Silicone Bronze ASTM B 371 Alloy 69400 or 69430
9. Body	Forged Brass ASTM B 283 Alloy C37700
10. Seat Ring	Virgin PTFE
11. Ball	1/4" - 3/4" & 2 1/2" - 4" 1" - 2" Chrome Plated Brass ASTM B 16 Alloy C36000 Chrome Plated Forged Brass ASTM 283 Alloy C37700
12. End Piece	Forged Brass ASTM B 283 Alloy C37700

Note: CSA, FM, UL and NSF approvals for T-FP-600N 1/2"-2" only.

CSA is now the approving agency for AGA and CGA standards.

Meets Dimensional Requirements of MSS SP110



T-FP-600N

Threaded



S-FP-600N

Solder

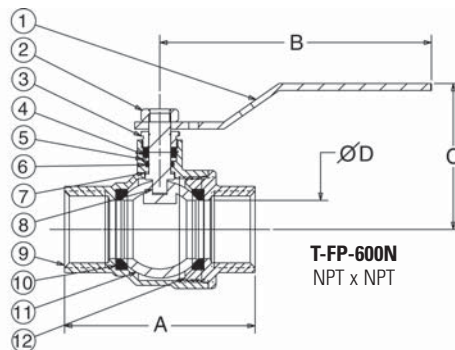

T-FP-600N
NPT x NPT

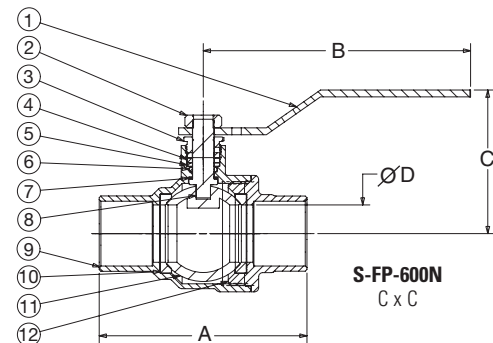

S-FP-600N
C x C

DIMENSIONS—WEIGHTS—QUANTITIES

Dimensions

Size	T-FP-600N		S-FP-600N		T-FP-600N		S-FP-600N		T-FP-600N		S-FP-600N		Port D	T-FP-600N		S-FP-600N		T-FP-600N Ctn. Qty.	S-FP-600N Ctn. Qty.		
	In.	mm.	In.	mm.	In.	mm.	In.	mm.	In.	mm.	In.	mm.		Lbs.	Kg.	Lbs.	Kg.				
1/4	8	1.98	50	—	—	3.90	99	—	—	1.95	49	—	—	.31	8	.52	.24	—	24	—	
3/8	10	1.98	50	2.02	51	3.90	99	3.90	99	1.95	49	1.95	49	.38	10	.49	.22	.46	.21	24	14
1/2	15	2.22	56	2.15	55	3.34	85	3.90	99	1.95	49	1.95	49	.50	13	.53	.24	.48	.22	18	18
3/4	20	2.66	67	2.94	75	3.34	85	4.66	118	2.30	58	2.30	58	.75	19	.96	.44	.90	.41	12	12
1	25	3.27	83	3.62	92	4.13	105	4.66	118	2.50	64	2.50	64	1.00	25	1.32	.60	1.25	.57	6	6
1 1/4	32	3.66	93	4.08	104	4.13	105	6.69	170	3.07	78	3.05	77	1.25	32	2.27	1.03	2.14	.97	4	4
1 1/2	40	3.96	100	4.63	118	5.13	130	6.69	170	3.25	83	3.23	82	1.50	38	3.12	1.42	2.94	1.33	2	2
2	50	4.66	118	5.78	147	5.13	130	6.69	170	3.55	90	3.55	90	2.00	51	4.52	2.05	4.46	2.02	2	2
2 1/2	65	5.56	141	6.38	162	9.44	240	9.90	252	4.25	108	4.25	108	2.50	64	7.00	3.18	7.30	3.32	5	1
3	75	6.38	162	7.36	187	9.44	240	9.90	252	5.00	127	4.65	118	3.00	76	9.40	4.27	10.40	7.73	4	1
4	100	7.75	197	—	—	9.44	240	—	—	5.25	140	—	—	4.00	102	16.50	7.49	—	—	4	—

