

*The top-of-the-line valve you can count on for superior durability and ability to handle exceptionally high pressures*



1" Globe



1½" Globe



2" Globe



3" Globe/Angle

**F**or a long-lasting valve that can deliver dependable performance at commercial sites, this is the heavy-duty workhorse you can count on. Created to handle the wide range of conditions different sites will bring, this valve includes both a fabric reinforced diaphragm and flow control as standard features, and can consistently withstand pressures of up to 220 PSI

while handling the continual hammer that such forces will produce. The ICV also offers the added option of the Accu-Set™ pressure regulator to maintain a safe, constant water pressure level. Plus, it's exceptionally easy to service, with bonnet fasteners that can be loosened and tightened using a variety of common contractor tools.

### Features & Benefits

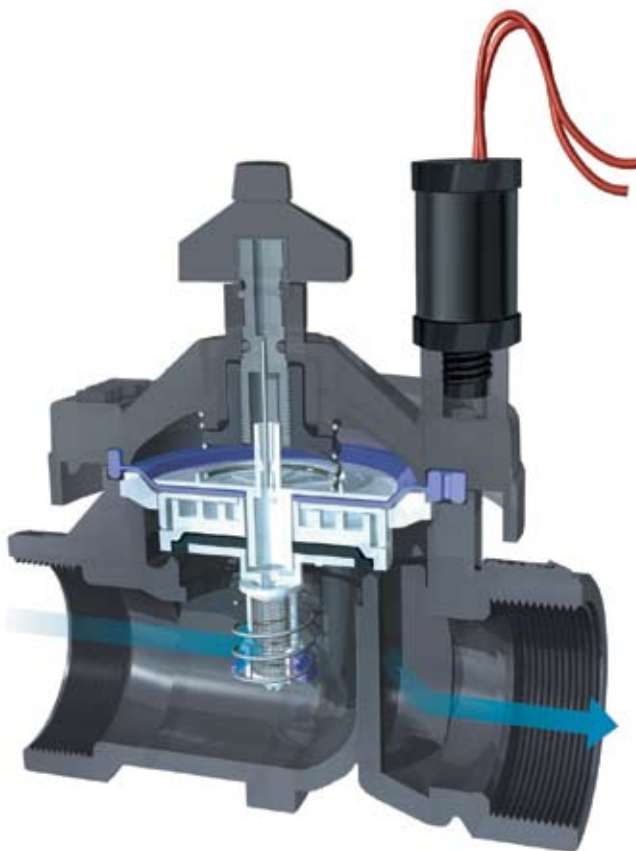

#### Glass-filled nylon construction

220 PSI rated for maximum strength and sturdiness

#### Internal and external manual bleed

Two options for manual operation

#### Captive solenoid plunger

No more lost parts when servicing

#### Captive bonnet bolts with matching brass body inserts

Provides ease of service, eliminates lost parts

#### Fabric reinforced EPDM diaphragm and EPDM seat

Provides reliable operation up to 220 PSI in all water conditions

#### Optional reclaimed water identification handle

For field identification of non-potable water supply

## Models

- ICV-101G – 1" plastic globe valve
- ICV-151G – 1½" plastic globe valve
- ICV-201G – 2" plastic globe valve
- ICV-301E – 3" plastic globe/angle valve
- Accu-Set™ Pressure Regulator

## Dimensions

- ICV-101G  
5½" H x 4¾" L x 4" W  
(14 cm H x 12 cm L x 10.2 cm W)
- ICV-151G  
7⅞" H x 6⅞" L x 5½" W  
(18 cm H x 17.5 cm L x 14 cm W)
- ICV-201G  
7⅞" H x 6⅞" L x 5½" W  
(18 cm H x 17.5 cm L x 14 cm W)
- ICV-301E  
10¾" H x 9¼" L x 7⅞" W  
(27.3 cm H x 23.5 cm L x 18.7 cm W)
- Female inlet/outlet: 1", 1½", 2" & 3" NPT or BSP

## Operating Specifications

- Flow: 0.10 to 300 GPM (0.06 to 68.10 m³/hr; 0.9 to 1,135.5 l/min)
- Pressure: 20 to 220 PSI (1.4 to 15.0 bars; 138 to 1500 kPa)
- Temperature: up to 150°F (66°C)
- Heavy-duty solenoid: 24VAC, 370mA inrush current, 190mA holding current, 60 cycles; 475mA inrush current, 230mA holding current, 50 cycles
- Accu-Set: 20 PSI (1.4 bars, 138 kPa) minimum operating pressure. Regulates from 20 to 100 PSI (1.4 to 7.0 bars; 138 to 689 kPa)

## Options Available

- Accu-Set pressure regulator
- Reclaimed water ID handle (part # 561205 - 1", 1½" & 2") (part # 515005 - 3")
- DC latching solenoid (part # 458200)
- Solenoid conduit cover (part # 464322)
- Drip Irrigation Valve Kit (part # ICZ101 and ICZ10140)



## Filter Sentry™: A Superior Self-cleaning System

Many traditional valve filters could become clogged by large amounts of small debris commonly found in reclaimed water, wells, or in lakes and ponds. But with Filter Sentry, the filter is scoured clean by a wiper that slides up and strokes the full length of the filter when the valve opens. The wiper continues to provide scrubbing action on the upper part of the filter during valve operation. For your convenience, Filter Sentry can be added easily after the valve is installed.

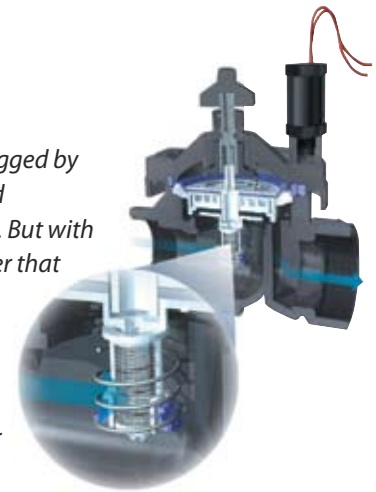

## Accu-Set™: Finally, a Pressure Regulator That's Easy to Set

With the added option of Accu-Set on a Hunter ICV valve, you can reliably adjust and regulate pressures anywhere from 20 to 100 PSI, and be certain the setting you select will never waver. Accu-Set can be field installed to any ICV valve in seconds, without tools. Plus, the best part is the ease of setting the unit—just turn to the pressure you want on the easy-reading dial. No other pressure regulating device is as simple to use (just one more reason to choose Hunter).



## ICV Pressure Loss in PSI

GPM	3"			
	1"	1½"	2"	Globe Angle
0.1	2.0			
0.5	2.0			
1.0	2.0			
5.0	4.0			
10.0	3.0			
15.0	3.0			
20.0	3.0	1.5		
30.0	4.0	1.5		
40.0	7.0	1.7	0.8	
50.0		2.2	1.2	
60.0		3.0	1.7	
75.0		3.9	2.4	
90.0		5.5	3.2	
100.0		7.0	4.2	
120.0		10.9	6.5	
135.0		12.7	7.9	
150.0	16.2	9.8	2.5	1.9
175.0		13.3	3.0	2.4
200.0		17.7	4.1	3.3
225.0			5.3	4.3
250.0			6.7	5.5
275.0			8.3	6.9
300.0			10.1	8.5

Charts based on full-open flow control position.



## SPECIFICATION GUIDE

EXAMPLE: **ICV - 201G - FS - AS**

MODEL ICV	FEATURES	OPTIONS FACTORY INSTALLED	OPTIONS USER INSTALLED
	101G = 1" Globe Valve	FS = Filter Sentry™	AS = Accu-Set™ Pressure Regulator
	151G = 1½" Globe Valve	B = BSP Threads	R = Reclaimed Water Identification Handle
	201G = 2" Globe Valve	DC = DC Latching Solenoid	CC = Conduit Cover
	301E = 3" Globe Valve		

## Hunter Industries Incorporated • The Irrigation Innovators

1940 Diamond Street • San Marcos, California 92078 • TEL: (1) 760-744-5240 • FAX: (1) 760-744-7461  
www.HunterIndustries.com

© 2006 Hunter Industries Incorporated

P/N 700683

LIT-233

3/06