

300BPE and 300BPES Valves Hybrid Performance and Value

Rain Bird's 3" BPE and BPES valves are built tough to offer long life and efficient, trouble-free performance - even under harsh conditions. Featuring a unique combination construction of brass body and glass-filled nylon bonnet, these valves are designed to withstand extreme pressure surges, effluent water and clogging debris. For additional protection, the BPES model is equipped with a patented scrubber mechanism to actively fight dirt and particles.

Features

- Unique hybrid construction featuring durable brass body and glass-filled nylon bonnet for long life and heavy-duty performance at 200 psi (13,80 bars).
- Globe and angle configuration for flexibility in design and installation.
- Manual internal and external bleed.
- External bleed does not allow debris to go through the solenoid ports when system is flushed. Internal bleed operates the valve without allowing water into the valve box; allows pressure regulator to be adjusted without turning the valve on at the controller first.
- Slow closing to prevent water hammer and subsequent system damage.
- Highly efficient operation with extremely low pressure loss.
- Flow control handle adjusts water flows as needed.
- **BPES only:** Nylon scrubber scrapes its stainless steel screen clean to break down grit and plant material. Prevents debris build-up and clogging.

Options (order separately)

- Accommodates optional, field-installed PRS-D pressure regulating module to ensure optimum sprinkler performance.
- Optional purple flow control handle for non-potable water applications. (BPE-NP-HAN)
- Accepts latching solenoid for use with Rain Bird battery-operated controllers up to 150 psi (10,35 bars).

Operating Range

- Pressure: 20 to 200 psi (1,38 to 13,80 bars)
- Flow with/without PRS-D: 60 to 300 gpm (13,62 to 68,10 m³/h; 3,78 to 18,90 l/s)
- Temperature: up to 150°F (66°C)

Electrical Specifications

- Power: 24 VAC 50/60 cycle solenoid
- Inrush current: 0.41 A (9.9 VA)
- Holding current: 0.23 A (5.5 VA)

Models

- 300BPE 3" (80/90)
- 300BPES 3" (80/90)

BSP threads available; specify when ordering.

Pressure Loss (psi)

gpm	Globe	Angle
60	7.5	6.8
80	7.4	7.1
100	7.3	6.8
120	5.8	5.2
160	1.8	1.8
200	2.2	1.9
250	3.3	2.6
300	4.9	3.5

Pressure Loss (bars)

m ³ /h	l/s	Globe	Angle
14	3,89	0,52	0,47
20	5,56	0,51	0,48
30	8,33	0,32	0,29
40	11,11	0,14	0,13
50	13,89	0,18	0,15
60	16,67	0,26	0,20
68	18,89	0,34	0,24

Notes

- 1) Loss values are with flow control fully open.
- 2) PRS-D module recommended for all flow rates.

Recommendations

- 3) Rain Bird recommends flow rates in the supply line not to exceed 7.5 ft./sec. (2,29 m/s) in order to reduce the effects of water hammer.
- 2) For flows below 5 gpm (1,14 m³/h; 0,32 l/s), Rain Bird recommends use of upstream filtration to prevent debris from collecting below the diaphragm.
- 3) For flows below 10 gpm (2,27 m³/h; 0,63 l/s) Rain Bird recommends the flow control stem be turned down two full turns from the fully open position.

Dimensions

Size	Height	Length	Width
300	13 ³ / ₈ " (34,61 cm)	8" (20,32 cm)	7"(17,78 cm)

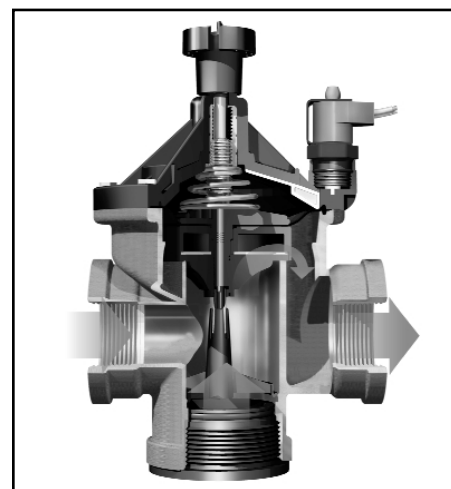
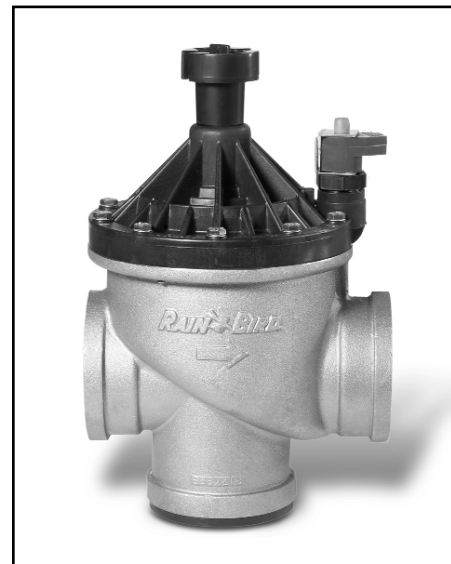

How to Specify

300-BPE-PRS-D

Size	Model	Optional Feature
300: 3"	BPE	PRS-D: pressure regulating module
300: 3"	BPES: scrubber model	

Note: Valve and PRS-D module must be ordered separately.



Specifications

The electric remote control valve shall be a normally closed 24 VAC 50/60 cycle solenoid actuated globe/angle pattern design. The valve pressure rating shall not be less than 200 psi (13,80 bars). The valve shall have the following characteristics (circle one):

Flow rate: _____ gpm m³/h l/s

Pressure loss not to exceed: _____ psi bars

The valve body and bonnet shall be a combination of heavy cast red brass body and heavy-duty glass-filled UV-resistant nylon bonnet and have stainless steel flange nuts. The diaphragm shall be of nylon reinforced nitrile rubber.

The valve shall have both internal and external manual open/close control (internal and external bleed) to manually open and close the valve without electrically energizing the solenoid. The valves internal bleed shall prevent flooding of the valve box.

The solenoid shall require 24 VAC 50/60 Hz power and open with 19.6 volt minimum at 200 psi (13,80 bars). At 24VAC, average inrush current shall not exceed 0.41 amps. Average holding current shall not exceed 0.23 amps.

The valve shall have a brass flow control stem for accurate manual regulation and/or shut-off of outlet flow. The valve must open or close in less than 1 minute at 200 psi (13,80 bars) and less than 30 seconds at 20 psi (1,38 bars).

The BPES valve shall have a self-cleaning stainless steel screen designed for use in dirty water applications.

The valve construction shall be such as to provide for all internal parts to be removable from the top of the valve without disturbing the valve installation.

Optional Feature Specification

PRS-D Pressure Regulating Module 300BPE-PRS-D, 300BPES-PRS-D

When so indicated on the design, the 3" electric remote control valve shall have a pressure regulating module (PRS-D) capable of regulating outlet pressure between 15 and 100 psi (± 3 psi) (1,04 and 6,90 bars ($\pm 0,21$ bars)).

The PRS-D module shall have an adjusting screw for setting pressure and Schrader valve connection for monitoring pressure. The pressure shall be adjustable from the PRS-D when the valve is internally manually bled or electrically activated.

Non-Potable Flow Control Handle BPE-NP-HAN

When so indicated on the design, the valve shall have a purple flow control handle to indicate to the user that non-potable water is being used. There shall be no difference between the black and purple handles except for the color.

The valve shall be as manufactured by Rain Bird Sprinkler Mfg. Corp., Glendora, California.

Heavy Duty 3" Remote Control Valve
Angle Installation

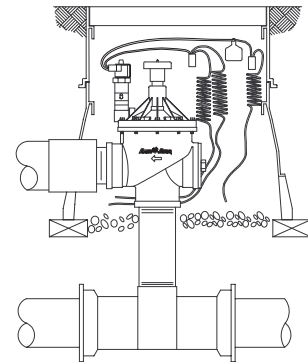

Heavy Duty 3" Remote Control Valve
Globe Installation

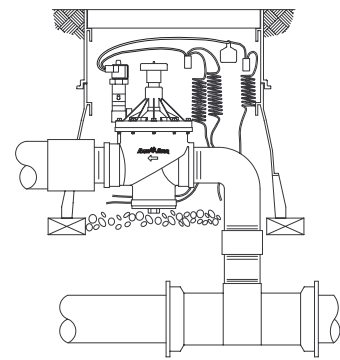

Rain Bird Corporation

Contractor Division
970 West Sierra Madre Avenue, Azusa, CA 91702
Phone: (626) 963-9311 Fax: (626) 812-3411

Rain Bird Corporation

Commercial Division
6991 East Southpoint Road, Tucson, AZ 85706
Phone: (520) 741-6100 Fax: (520) 741-6146

Rain Bird International, Inc.

145 North Grand Avenue, Glendora, CA 91741
Phone: (626) 963-9311 Fax: (626) 963-4287

Rain Bird Technical Service

(800) 247-3782 (U.S. only)

www.rainbird.com

Rain Bird. Conserving More Than Water.

© Registered trademark of Rain Bird Sprinkler Mfg. Corp.
© 2001 Rain Bird Sprinkler Mfg. Corp. 3/01

D37145F